

LAKE COUNTRY 

PRODUCT CATALOG

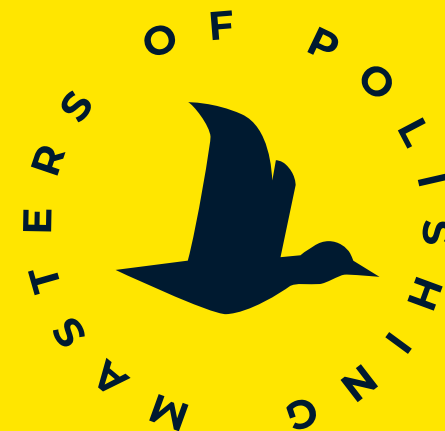

TO ALL OUR CUSTOMERS

Whether you're a friend who gave advice along the way, someone who helped introduce our products to the world, a professional in the field or an avid hobbyist, thank you.

You are part of our success at Lake Country Manufacturing and the momentum to keep developing the best buffing and polishing products that can be built. We appreciate your feedback and support in our industry.

- Schneider Family

QUICK TIP

Like the catalog?
Find even more information
on our website at
LakeCountryMFG.com



CONTENTS

AN INDUSTRY LEADER

With 69 patents worldwide, Lake Country has been an industry leader in the development of innovative polishing tools, pads, and accessories. For decades, Lake Country has continued to raise the bar, and evolve to fit the needs of our constantly growing and changing market.

DECADES OF EXPERTISE

We have over 100 years of in-the-trenches, hands-on experience covering all aspects of body work, painting and buffing in the automotive, marine and aerospace industries. Lake Country's facility and testing operations are set-up to fully utilize measuring equipment and perform quantitative product evaluations to develop innovative products for the buffing and polishing industry across the world.

| | |
|---|----|
| DESIGNED FOR EVERY UNIQUE MARKET | 04 |
| TOOL GUIDE | 05 |
| SYSTEM 4000™ PAD WASHER | 06 |
| HANDHELD DETAILING LIGHT | 08 |
| MARINEMASTER™ BUFFING SYSTEM | 10 |
| OUR PADS EXPLAINED | 12 |
| WHAT IS CCS TECHNOLOGY? | 14 |
| LC SPECIALTY LINES | 16 |
| HDO®, SDO™, SDO™ Mini, UDO™, Force™ | |
| MICROFIBER PADS | 26 |
| KNITTED PADS | 28 |
| Low Lint, Purple Foamed Wool, Blue Foam Wool, | |
| TRADITIONAL WOOL PADS | 32 |
| ROTARY & DA PLATES | 34 |
| DETAILERS BACKPACK | 36 |
| ACCESSORIES | 38 |
| Rotary Extensions, Precision Applicators, Microfiber Towels, Snappy Clean | |

DESIGNED FOR EVERY UNIQUE

MARKET

QUICK TIP

In every listed catalog we serve PBE, automotive, marine, aviation and composite industries.



DETAILING

The wide variety of product choices available to your buyers can be overwhelming. Lake Country will work with you to be sure you have the best mix of premium products to satisfy both professionals and DIY/hobbyists. We also know the importance of competitive pricing, fast delivery, and ongoing new product development to meet customer demands.

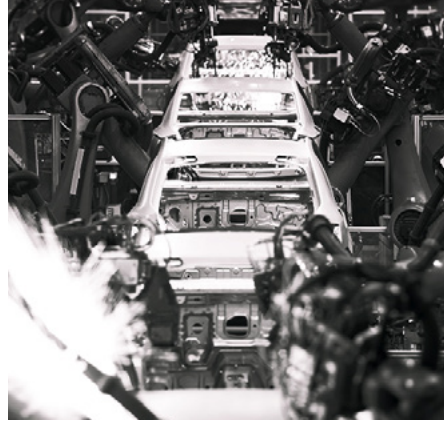

INDUSTRIAL

Lake Country designs industrial products that provide consistent, high-quality performance that is critical for our customers to get their job done. We know how important it is for customers to have the product when they need it to keep production lines running—that's why we provide stock build programs to ensure on-time delivery.



PAINT & BODY

Lake Country offers a full line of quality buffing and polishing products ranging from traditional wool pads, foam pads and our patented scuff balls that many PBE customers trust to get the job done. We know time is money and our products deliver the best results with the least amount of effort so technicians can move to the next job quickly.



PRIVATE LABEL

We understand the needs of enthusiasts as well, as professional detailers alike. That is why Lake Country offers a range of products including foam cutting pads, polishing pads, finishing pads, wool pads, microfiber pads and much more. We understand how important it is to have the tool, for every task. That is why our range offers a variety of sizes, densities, and configurations to suit your polishing needs.

RECOMMENDED TOOLS

TOOL GUIDE

Every technician or professional has a tool that helps them get the job done. Our trade is no different. We developed our products with professional and consumer grade products in mind and recommend the right tool for our pad lines.

01

RANDOM ORBITAL DA

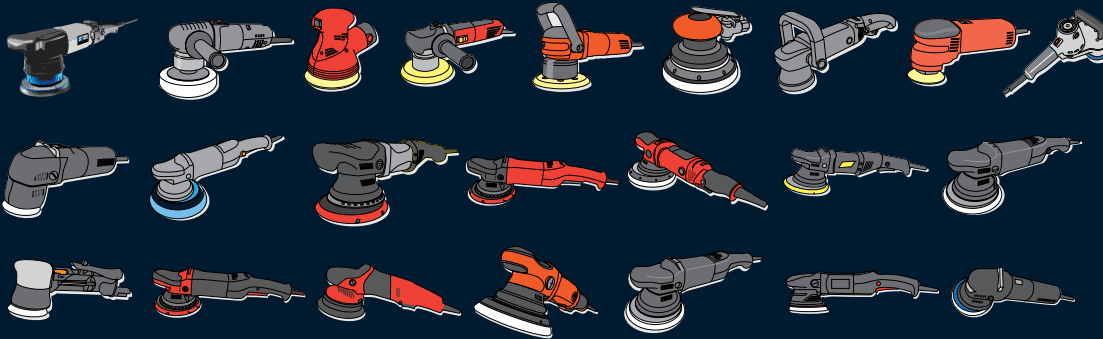

02

ROTARY



03

FORCED DUAL ACTION



04

MINI POLISHER





PAD WASHER

Patented Worldwide. The System 4000™ with Pure Flo Technology is a self-contained cleaning system featuring a user controlled pump and a removable catch basin. The first cleaning system that pumps fresh cleaning solution into the pad every time while containing the contaminated water separately.

Easy and effective to use for most types of pads and polishers with easy access to clean pads on the go. This environmentally friendly, water-saving unit is perfect for applications where cleaner pads with less contamination are essential.

| Description | Part Number |
|--|-------------|
| System 4000 Pad Washer Pure Flo™ Technology | 90-4000 |





SNAPPY CLEAN BOOST™

A concentrated cleaner that releases wax and polish from the foam or wool pads with just a few minutes of soaking. Add a spoonful to your System 4000 water for optimal performance. Biodegradable, non-flammable, and rinses out easily.

| Description | Part Number |
|--|-------------|
| Snappy Clean Boost™ (Citrus 1.25 oz. packet) | 92-003 |
| Snappy Clean Boost™ 5l bucket | 92-002-5l |

FEATURES

- **Pure Flo Technology**
Separates new cleaning solution from the old and used solution, resulting in a fresh clean pad every time
- **Compatible**
Works with Random Orbital, DA, and Rotary polishers as well as all sizes and types of pads – wool and foam from 3 to 7
- **Environmentally Friendly**
System 4000 uses only 1.6 gallons of water (50% less than other pad washers)
- **Fluted Wash Plate**
Cleans effectively without damaging pads



New Carry System

Increased comfort and ease of use with revised center of gravity.



Redesigned Wash Plate

Heavy structure for increased durability combined with new sealing technology.



Open Top Design

Deep, open access allows for convenient use without unintentional water spray.



Improved Pump Design

Eliminating pressure loss while reducing clogging.



HANDHELD DETAILING

LIGHT

The handheld detailing light is new from LC Power Tools, a Lake Country MFG subsidiary. Designed to be comfortable, long-lasting, robust, and featuring brightness settings optimized for the needs of all detailing professionals and enthusiasts – see what you’re missing, with the Handheld Detailing Light.

FEATURES

- Powerful flip out magnetic base for ultra-convenient positioning
- 1350 Lumens - a brightness typically not available in a handheld application
- Up to 6 hour battery life with a USB charger
- Dual brightness modes optimized for swirl and scratch detection

| Description | Part Number |
|----------------|-------------|
| Handheld Light | 25-1350 |





SCAN HERE TO
LEARN MORE

Never Miss a Defect Again!

Whether working in a professional studio, body shop, home garage or driveway, the Handheld Detailing Light is an essential companion. No tool is more important for assessing the task at hand, or the results you've expertly achieved!



Convenient USB Quick Charge Port

Universal compatibility for charging on the go



Practical Fold Out Stand

Positioning at any angle with the strong magnetic base

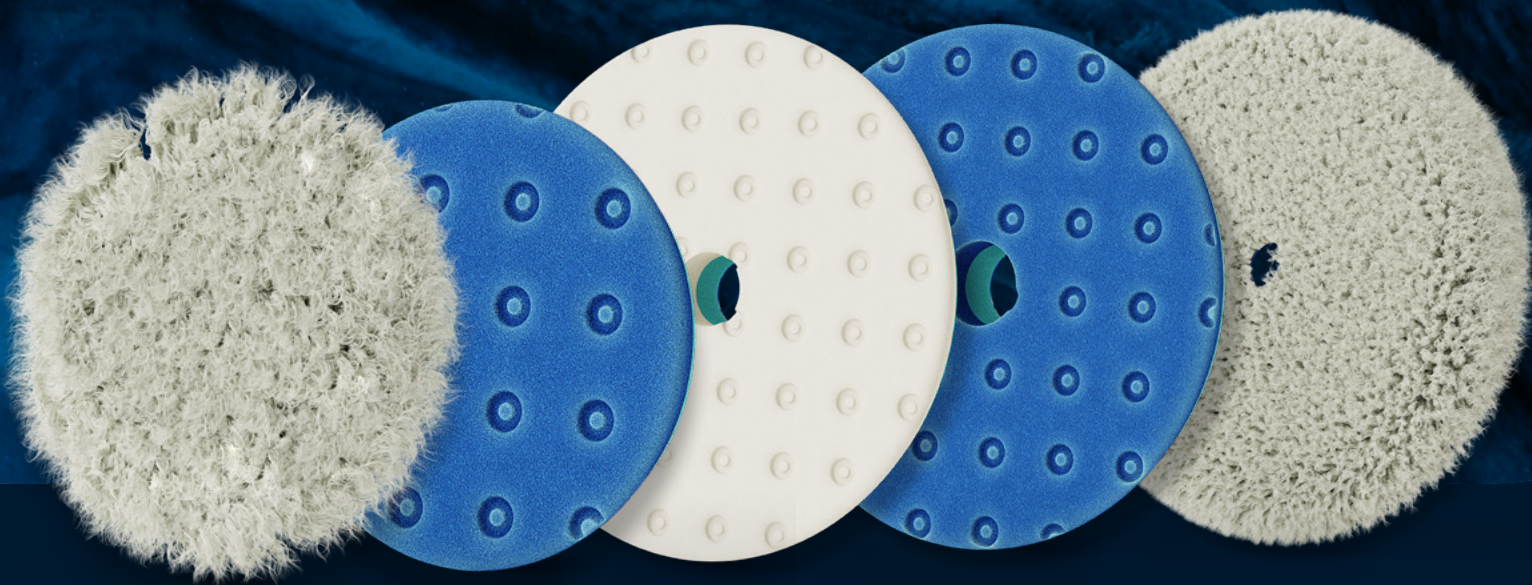

MarineMaster™

INTRODUCING THE MARINEMASTER™ BUFFING SYSTEM

Leveraging many decades of expertise in manufacturing high-quality buffing pads, Lake Country MFG proudly presents the MarineMaster™ range—our most advanced system yet for the detailing and boat cleaning trade. As industry leaders who understand the unique challenges faced by professionals, we've meticulously engineered this complete buffing system to meet the specific demands of gel coat surfaces.

Ensure your clients' vessels and RVs maintain their pristine appearance with our innovative pad offerings designed for every step of the buffing process.

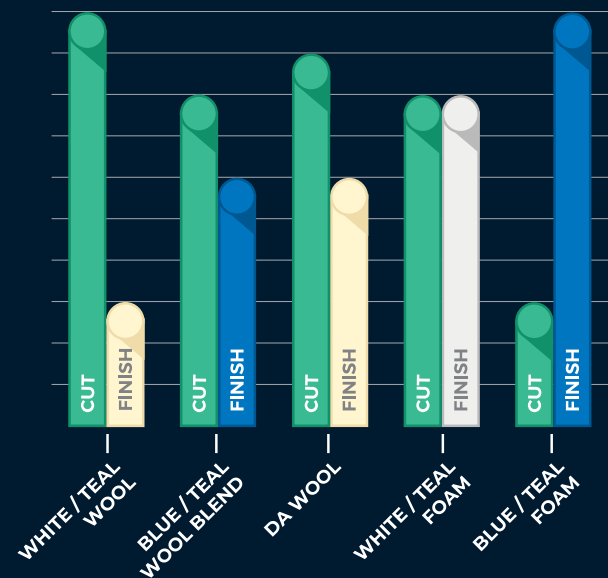

WORKS ON



Boats



RVs



for use on Gelcoat, Aluminum & painted surfaces.

PRODUCT RANGE



Rotary Wool

Cutting

FEATURES

- Unique blend of all natural twisted fibers
- Recessed backing
- Hook & loop attachment
- 5/8-11" double-sided attachment

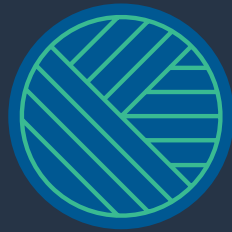

Rotary Polishing Wool

Cutting

FEATURES

- Natural & synthetic blend of twisted wool
- Recessed backing
- Hook & loop attachment
- 5/8-11" double-sided attachment



DA Wool

Cutting

FEATURES

- 100% twisted wool fibers
- Flexible foam interface
- Center hole for heat dissipation & alignment
- Hook & loop attachment

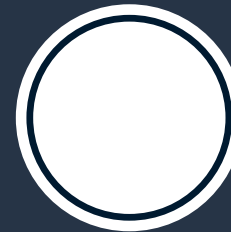

DA Correcting Foam

Medium Duty

FEATURES

- Rigid correcting foam
- Flexible foam interface
- Center hole for heat dissipation & alignment
- Hook & loop attachment



DA Polishing-Foam

Finishing

FEATURES

- Soft polishing foam
- Flexible foam interface
- Center hole for heat dissipation & alignment
- Hook & loop attachment

OUR PADS EXPLAINED

Most typical foam pads are constructed with an open-cell material, a very porous structure. Whether they be coarse and firm, or smooth and plush, open-cell foams will always allow a certain amount of your compound or polish to soak beneath the surface and, even though this is a natural part of the process, we recognize that there could be efficiency gains by keeping more of that abrasive media in action for longer.

Our CCS (Collapsed Cell Structure) technology refers to an even distribution of formed dimples imprinted into the pad face. By 'collapsing' the cells inside those dimples we close them off, creating reservoirs that prevent compound from being absorbed into the pad.

But there's more to it than that!

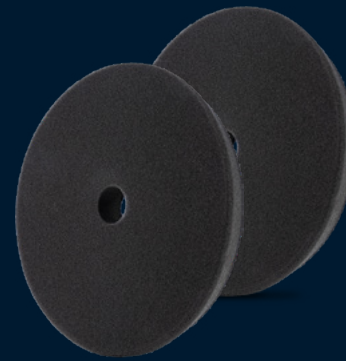

SDO™ PADS

Perfect for 'everyday' pads suited to standard orbital polisher.

Center hole ventilation for lower temperatures and easy fit.

Tapered edge prevents pad rolling & provides great pad rotation.

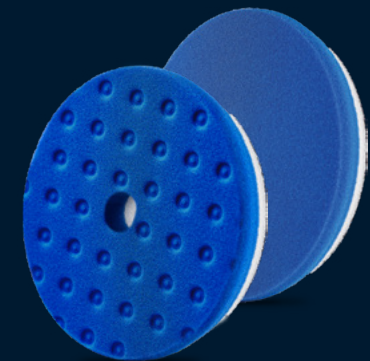

HDO® PADS

Dual layer construction unleashes the full potential of larger throw orbital polishers.

Increased performance and durability under heavier load.

| Defect Severity | Paint Hardness | Recommended Foam Choice | |
|--------------------|----------------|-------------------------|-----------|
| Heavy | Hard | Blue | |
| | Medium | Blue | |
| | Soft | Blue | or Orange |
| Medium | Hard | Blue | |
| | Medium | Blue | or Orange |
| | Soft | Orange | |
| Light | Hard | Blue | or Orange |
| | Medium | Orange | |
| | Soft | Orange | or Black |
| Ultra Light / Haze | Hard | Orange | or Black |
| | Medium | Black | |
| | Soft | Black | |

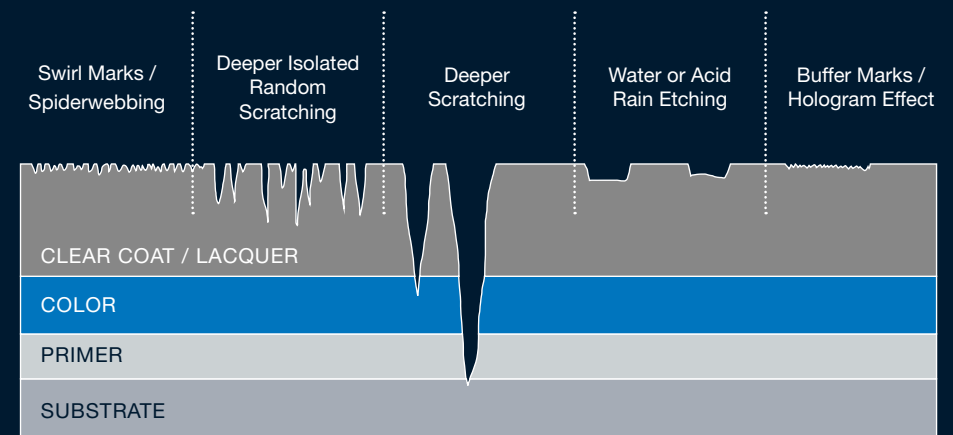

PADS OVERVIEW

Variable severity of paint defects and hardness mean we need a choice of pads to suit each task. Our simple three color system makes it easy to know which pad you need.



CORRECTION

USE FOR:

Heavy defects, harder paint surfaces, deep etching

USE WITH:

Medium to heavy cutting compounds

Our Blue foam offers great cut to tackle tired paint surfaces, correcting moderate scratches and scuffs, bird bomb etchings and removing everyday swirl marks with ease.

CUT

FINISH



POLISH

USE FOR:

Fine scratches & general light swirls

USE WITH:

Medium cut compound or polish

The Orange pad can be used as a cutting pad on softer paints or when defects are not too severe to begin with. On harder paint surfaces, the orange foam acts as the perfect choice for finishing to a brilliant gloss.

CUT

FINISH



FINISH

USE FOR:

Final refinement, jewelry & very light swirls on soft paint

USE WITH:

Extra fine finishing polish

The Black foam works to refine your corrected surface to a flawless gloss, removing any trace of cutting haze from the correction stage(s) above. On very soft paints, the Black foam could also work as a one-step to remove very light swirls and finish perfectly in one go.

CUT

FINISH



WHAT IS

CCS TECHNOLOGY?

Most typical foam pads are constructed with an open-cell material, a very porous structure. Whether they be coarse and firm, or smooth and plush, open-cell foams will always allow a certain amount of your compound or polish to soak beneath the surface and, even though this is a natural part of the process, we recognize that there could be efficiency gains by keeping more of that abrasive media in action for longer.

Our CCS (Collapsed Cell Structure) technology refers to an even distribution of formed dimples imprinted into the pad face. By 'collapsing' the cells inside those dimples we close them off, creating reservoirs that prevent compound from being absorbed into the pad.

But there's more to it than that!

WHAT DIFFERENCE DOES CCS MAKE?

CCS provides a number of advantages in terms of operational efficiency, user comfort and control, and even cost savings.

EVEN PRODUCT DISTRIBUTION

Lake Country recommends ensuring that your compound or polish is evenly spread across the whole pad face before and during every pass, so that the whole pad face is performing optimally. CCS gives a useful visual guide for priming!

LONGER/LARGER PASSES

Compound is most abrasive when it's fresh from the bottle. As they diminish, most compounds will lose a large amount of their cut meaning the detailer may need to frequently stop to apply more. By effectively storing some fresh compound in reserve on the pad face, CCS allows detailers to 'refresh' their cut and increase the size and duration of their pass with a simple squeeze of the pad – potentially saving time through a less interrupted workflow.



REDUCED TEMPERATURES

CCS dimples act as air pockets – useful for keeping temperatures lower than an equivalent flat pad face would do. You'll notice CCS pads feel smoother, more cushioned and less 'grabby' in use than their flat-faced counterparts.

INCREASED DURABILITY

Even when worked for longer, pads with CCS tend to outlast the competition thanks to the slightly different ways the pad face, compound/polish and paintwork interact. Your compound will have a longer 'aggressive' lifespan, despite the pad design itself offering slightly less cut as a result of the reduced overall surface area. When combined with the maximized durability through a reduction in temperatures, it's easy to see why CCS pads offer better value for money for the detailer!

PREMIUM QUALITY

HDO® PADS

Designed for long throw polishers specifically, the heavy duty orbital (HDO®) line was created to offer more durable and performance enhancing characteristics. The dual layer design allows these pads to capture all the benefits that come with not only a tapered pad, like anti-roll and backing plate protection, but the benefits of even compression like an exact fit pad. It features the benefits of a thin pad, such as increased power and reduced pad motion, while still retaining the proper weight and balance for proper rotation.

HDO® PADS AGGRESSION CHART

Each bar color coordinates with the applicable pad color.

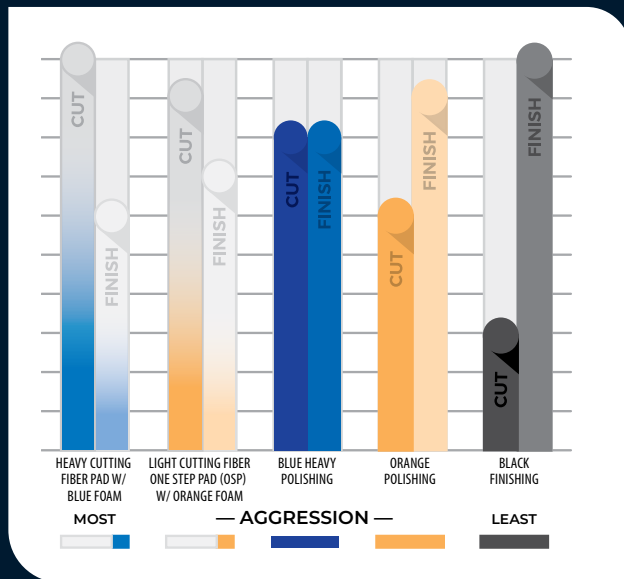

NEW PRODUCT

New introduction is the HDO® product featuring CCS Technology™

DUAL LAYER DESIGN

Dual layers reduce heat transfer & lateral movement for less foam fatigue.

CENTER VENTILATED COOLING CHANNEL

Dissipates heat away from the center of pad, reducing temperature, increasing durability.

TAPERED EDGE

Prevents pad rolling & provides great pad rotation.

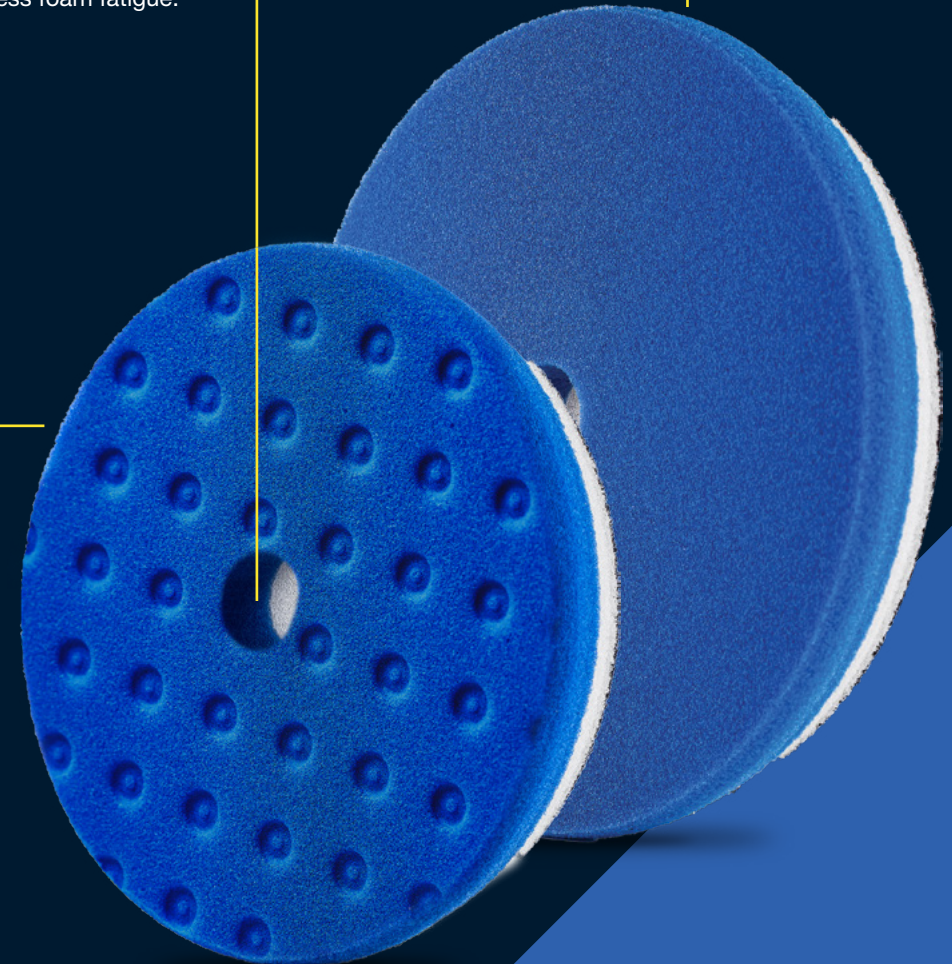

PRODUCT RANGE

| HDO® Microfiber & Foam Pads | Description | Thickness | 6-1/2" Fits 6" Backing Plate | 5-1/2" Fits 5" Backing Plate | 3-1/2" Fits 3" Backing Plate | Quantity |
|-----------------------------|--|-----------|------------------------------|------------------------------|------------------------------|----------|
| | | | | | Recommended Tools 4 | |
| | Heavy Cutting Fiber Pad w/ Blue Interface | 1/2" | HDO-650F-LC | HDO-550F-LC | HDO-350F-LC | |
| | Light Cutting Fiber One Step Pad (OSP) w/ Orange Interface | | HDO-650F-OSP | HDO-550F-OSP | HDO-350F-OSP | |
| | Blue Heavy Polishing Pad | 1" | HDO-93650-LC | HDO-93550-LC | HDO-93350-LC | |
| | Blue Heavy Polishing Pad w/ CCS Technology | | HDO-93650-CCS-LC | HDO-93550-CCS-LC | HDO-93350-CCS-LC | |
| | Orange Polishing Pad | | HDO-23650-LC | HDO-23550-LC | HDO-23350-LC | |
| | Orange Polishing Pad w/ CCS Technology | | HDO-23650-CCS-LC | HDO-23550-CCS-LC | HDO-23350-CCS-LC | |
| | Black Finishing Pad | | HDO-73650-LC | HDO-73550-LC | HDO-73350-LC | |
| | Black Finishing Pad w/ CCS Technology | | HDO-73650-CCS-LC | HDO-73550-CCS-LC | HDO-73350-CCS-LC | |

PROFILE

Attachment method: Hook & loop

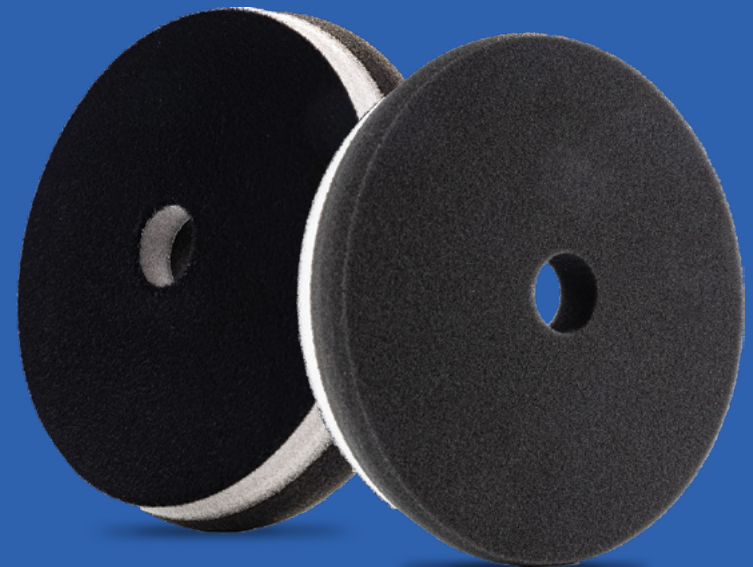
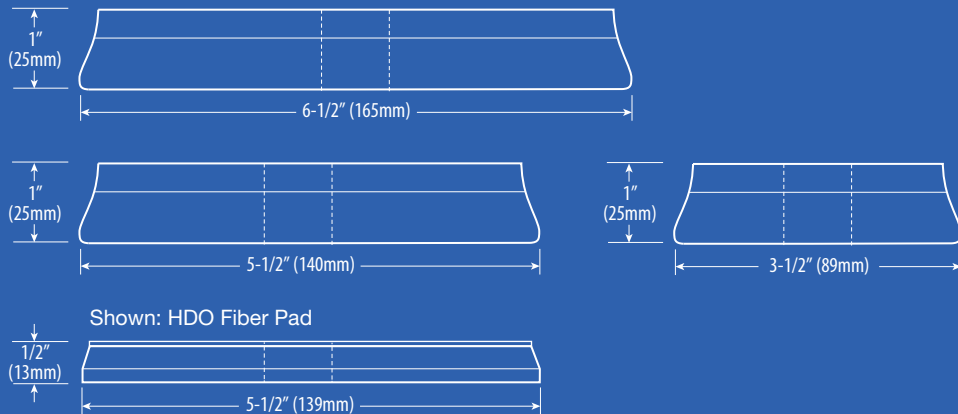

EVERYDAY ESSENTIAL

SDO™ PADS

Standard Duty Orbital (SDO™) pads have been designed to offer the same great engineered foams as the HDO® line without the dual layer construction and are suitable for all random orbital DA polishers with a center ventilated backing plate. The center hole provides a tunnel to release and dissipate heat from the foam; reducing surface temperatures making it less likely to damage the paint.

SDO™ PADS AGGRESSION CHART

Each bar color coordinates with the applicable pad color.

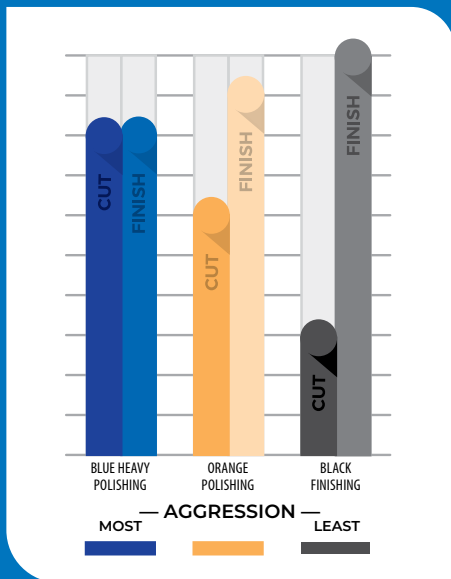

NEW PRODUCT

SDO™ foam pads are now available as 2 & 1" mini pads

SDO™ FORMULATION

SDO foams provide maximum durability & consistency.

CENTER VENTILATED COOLING CHANNEL

Dissipates heat away from the center of pad, reducing temperature, increasing durability.

TAPERED EDGE

Prevents pad rolling & provides great pad rotation.

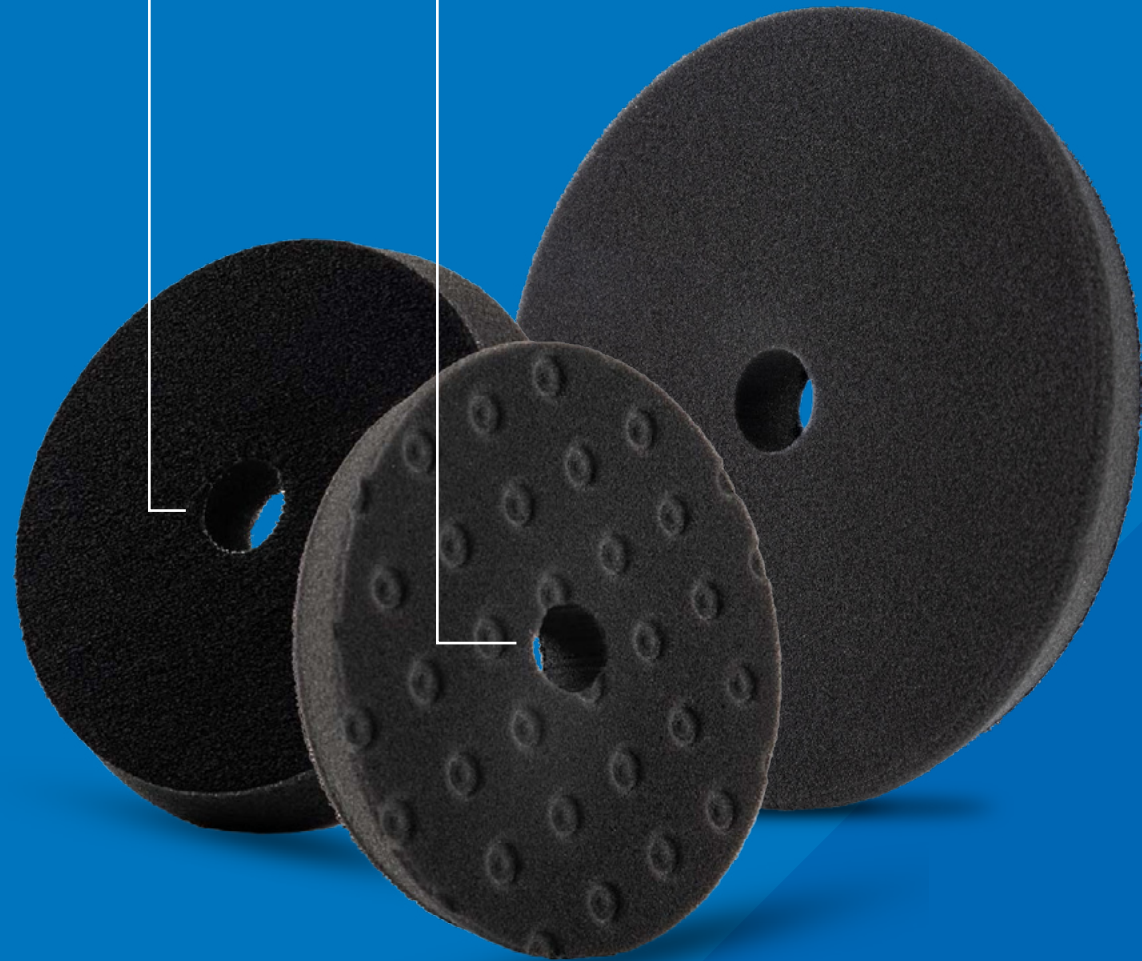





01 RANDOM ORBITAL DA

03 FORCED DA

04 MINI POLISHER

PRODUCT RANGE

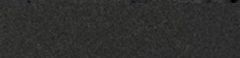
| SDO Foam Pads | Description | Thickness | 6-1/2" Fits 6" Backing Plate | 5-1/2" Fits 5" Backing Plate | 3-1/2" Fits 3" Backing Plate | Quantity |
|---|--|-----------|------------------------------------|------------------------------------|------------------------------------|----------|
|  | Blue Heavy Polishing Pad w/ CCS Technology | 7/8" | SDO-92650-CCS-LC | SDO-92550-CCS-LC | SDO-92350-CCS-LC | |
|  | Blue Heavy Polishing Pad | | SDO-92650-LC | SDO-92550-LC | SDO-92350-LC | |
|  | Orange Polishing Pad w/ CCS Technology | 7/8" | SDO-22650-CCS-LC | SDO-22550-CCS-LC | SDO-22350-CCS-LC | |
|  | Orange Polishing Pad | | SDO-22650-LC | SDO-22550-LC | SDO-22350-LC | |
|  | Black Finishing Pad w/ CCS Technology | 7/8" | SDO-72650-CCS-LC | SDO-72550-CCS-LC | SDO-72350-CCS-LC | |
|  | Black Finishing Pad | | SDO-72650-LC | SDO-72550-LC | SDO-72350-LC | |

PROFILE

Attachment method: Hook & loop

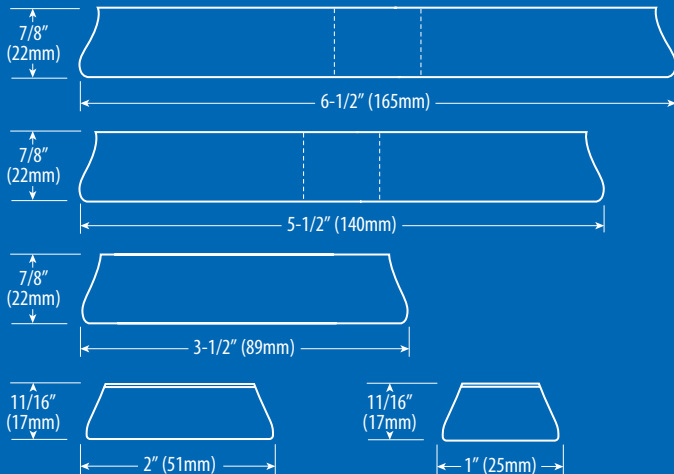

FOR TRICKY SPOTS

SDO™ MINI PADS

Our signature three-stage range of premium foam pads, now perfectly sized and contoured to make polishing in tighter spots a breeze. Effective on all mini polishers (rotary or orbital), SDO™ Mini pads are the best way to correct and polish defects in air ducts, around badges, on narrow panels, trims and more. Use SDO™ Minis to compliment your full-size HDO® or SDO™ pad collection, and reach new heights of perfection.

SDO™ MINI PADS AGGRESSION CHART

Each bar color coordinates with the applicable pad color.

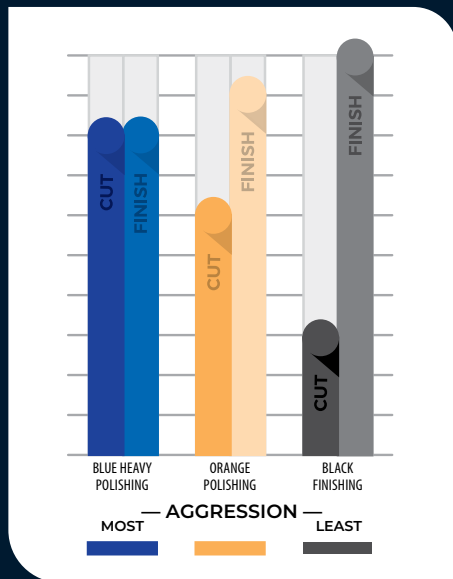



QUICK TIP
For even greater cutting action, consider our Mini Microfiber pads (also available in 2" and 1" options)"

TAPERED EDGE
Prevents pad rolling & provides great pad rotation.



PRODUCT RANGE

| SDO™ Mini Pads | Description | Size | 2 1/2" Fits 2" Backing Plate | 1 3/4" Fits 1" Backing Plate | Quantity |
|---|--------------------------|--------|---------------------------------|---------------------------------|----------|
|  | Blue Heavy Polishing Pad | 11/16" | SDO-98250-LC | SDO-98150-LC | |
|  | Orange Polishing Pad | | SDO-28250-LC | SDO-28150-LC | |
|  | Black Finishing Pad | | SDO-78250-LC | SDO-78150-LC | |

PROFILE

Attachment method: Hook & loop

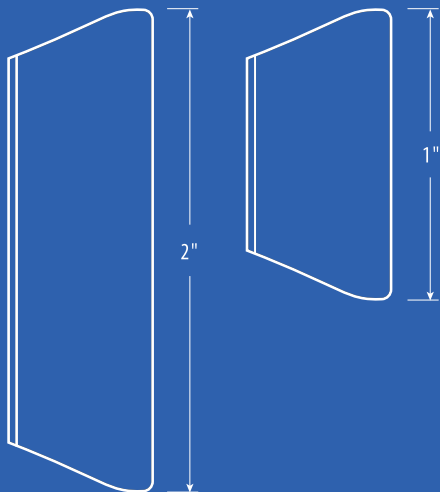

MICROWOOL AND FOAM

UDO™ PADS

The new line of UDO™ pads complement the 5-in-1 of the UDOS 51E functionality and the unique backing plate. UDO™ custom pads are designed to operate in rotary or dual action orbit modes (12mm, 15mm, 21mm). The new UDO™ polishing pad line features the exclusive Active Rebound Technology.

UDO™ PADS AGGRESSION CHART

Each bar color coordinates with the applicable pad color.

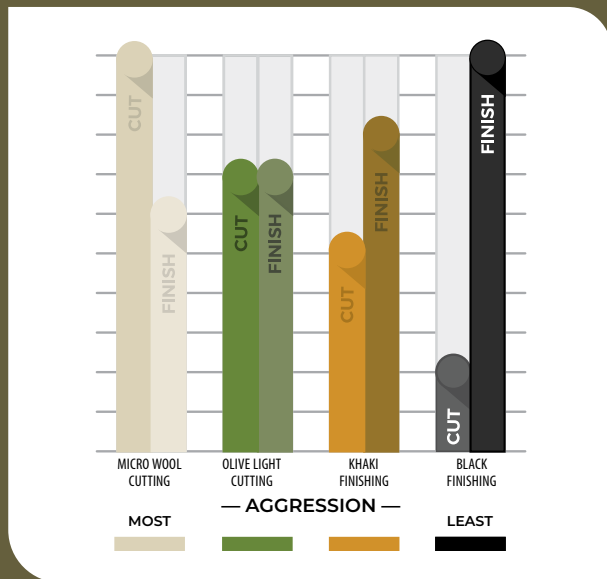

TAPERED PROFILE

Get into hard to reach places without risking damage from the backing plate.

ACTIVE REBOUND TECHNOLOGY

Keeps pad from flattening out and losing buoyancy for the entire polishing process.

VERSATILE

UDO pads are designed to work on both Random Orbital and Rotary polishing machines.



RECOMMENDED TOOLS

01

RANDOM ORBITAL DA





02

ROTARY

03

FORCED DA

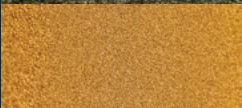
PRODUCT RANGE

| UDO Pads | Description | Thickness | 3-1/2" | 4" | 5-1/2" Fits 5" Backing Plate | 6" | 6-1/2" | 7" | Quantity |
|---|-------------------------|-----------|--------|----|------------------------------------|----|--------|----|----------|
|  | Microwool Cutting Pad | 1/2" | | | 25-0100 | | | | |
|  | Olive Light Cutting Pad | 1" | | | 25-0101 | | | | |
|  | Khaki Polishing Pad | | | | 25-0102 | | | | |
|  | Black Polishing Pad | | | | 25-0103 | | | | |

PROFILE

Attachment method: Hook & loop

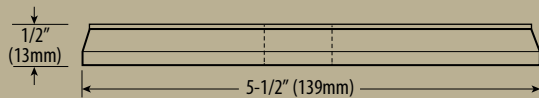
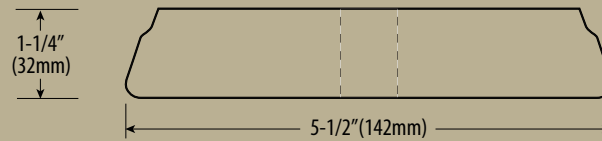
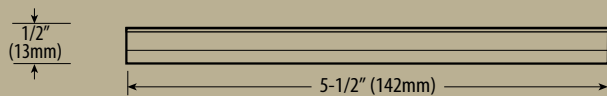

FORCE™ PADS

FEATURING HYBRID FOAM TECHNOLOGY

Force™ hybrid foams are specifically engineered with small cells and dense, robust construction to maximize performance when used on a forced rotation machine polisher. This results in faster correction time as more polish stays on the working surface rather than being absorbed into the foam.

FORCE™ PADS AGGRESSION CHART

Each bar color coordinates with the applicable pad color.

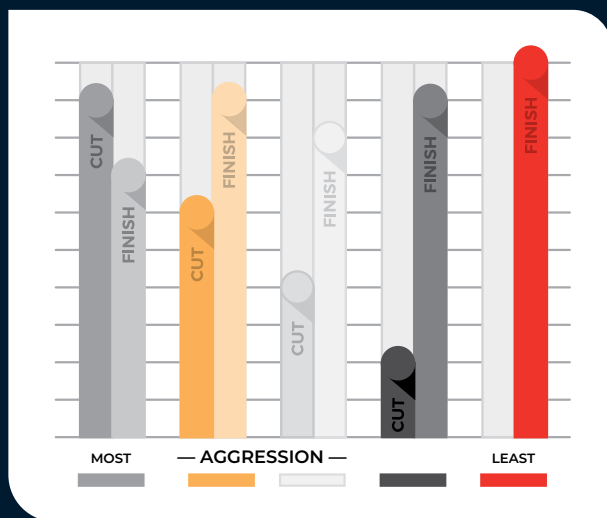

CENTER VENTILATED COOLING CHANNEL

Dissipates heat away from the center of pad, reducing temperature, increasing durability.

FORCE HYBRID FOAM

Small cells & dense construction uses less polish for quicker results. polishing machines.

TAPERED EDGE

Prevents pad rolling and provides great pad rotation.



RECOMMENDED TOOLS

PRODUCT RANGE

02 ROTARY 03 FORCED DA 04 MINI POLISHER

| Force Pads | Description | Thickness | 6-1/2" | 5-1/2" | 3-1/2" | 2-3/8" | 1-5/8" | Quantity |
|-----------------------------|-------------|-----------|-----------------------|-----------------------|-----------------------|-----------------------|---------------------------|----------|
| | | | Fits 6" Backing Plate | Fits 5" Backing Plate | Fits 3" Backing Plate | Fits 2" Backing Plate | Fits 1-1/4" Backing Plate | |
| | | | Recommended Tool 3 | Recommended Tool 3 | Recommended Tool 2 | Recommended Tools 4 | Recommended Tools 4 | |
| Grey Heavy Cutting Foam Pad | | 11/16" | | | | FR-HGrey 2"-LC | FR-HGrey 1"-LC | |
| | | 7/8" | | | FR-HGrey 3.5"-LC | | | |
| | | 1-1/4" | FR-HGrey 6.5"-LC | FR-HGrey 5.5"-LC | | | | |
| Orange Cutting Foam Pad | | 11/16" | | | | FR-HOrange 2"-LC | FR-HOrange 1"-LC | |
| | | 7/8" | | | FR-HOrange 3.5"-LC | | | |
| | | 1-1/4" | FR-HOrange 6.5"-LC | FR-HOrange 5.5"-LC | | | | |
| White Polishing Foam Pad | | 11/16" | | | | FR-HWhite 2"-LC | FR-HWhite 1"-LC | |
| | | 7/8" | | | FR-HWhite 3.5"-LC | | | |
| | | 1-1/4" | FR-HWhite 6.5"-LC | FR-HWhite 5.5"-LC | | | | |
| Black Finishing Foam Pad | | 11/16" | | | | FR-HBlack 2"-LC | FR-HBlack 1"-LC | |
| | | 7/8" | | | FR-HBlack 3.5"-LC | | | |
| | | 1-1/4" | FR-HBlack 6.5"-LC | FR-HBlack 5.5"-LC | | | | |
| Red Waxing Foam Pad | | 11/16" | | | | FR-HRed 2"-LC | FR-HRed 1"-LC | |
| | | 7/8" | | | FR-HRed 3.5"-LC | | | |
| | | 1-1/4" | FR-HRed 6.5"-LC | FR-HRed 5.5"-LC | | | | |

PROFILE

Attachment method: Hook & loop

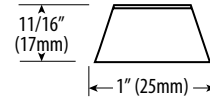
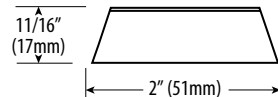
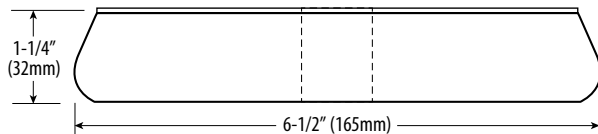

DURABILITY AND LONGEVITY

MICROFIBER PADS

With years of testing, a complete line of microfiber pads were created to tackle any job with a random orbital DA polisher. Using specific blends of microfiber and special bonding materials, we created these pads to have durability and longevity that is tough to compete with. Each pad offers its own unique blend of microfiber, paired with the appropriate foam interface to suite each purpose.

HDO Microfiber pads complement our HDO foams, with optimized performance on long throw polishers through the addition of a tapered edge profile and center cooling channel

MICROFIBER PAD AGGRESSION CHART

Each bar color coordinates with the applicable pad color.

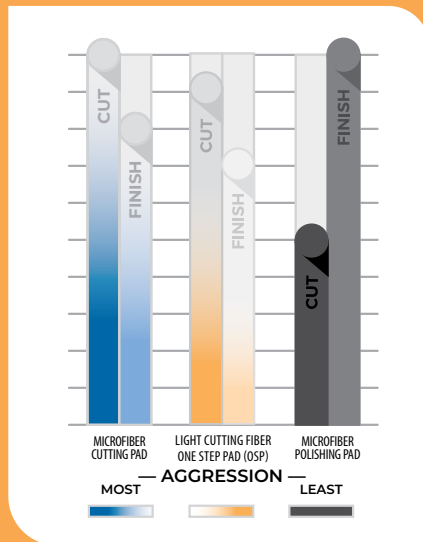

FOAM INTERFACE

Foam provides greater durability and is optimized for user experience.

SPECIALTY BLEND OF MATERIAL

Provides an amazing finishing ability resulting in a haze free luster.

PRECISION SIZING

Minimal overhang for precision polishing and even pressure.



RECOMMENDED TOOLS

01 RANDOM ORBITAL DA

04 MINI POLISHER

PRODUCT RANGE

| Microfiber Pads | Description | Thickness | 6-1/4" Fits 6" Backing Plate | 5-1/4" Fits 5" Backing Plate | 3-1/4" Fits 3" Backing Plate | 2-1/4" Fits 2" Backing Plate | 1-1/2" Fits 1" Backing Plate | Quantity |
|---|--|-----------|---------------------------------|---------------------------------|---------------------------------|---------------------------------|---------------------------------|----------|
|  | Microfiber White Cutting Pad (No center hole) | 1/2" | MF-625 CUT-LC | MF-525 CUT-LC | MF-325 CUT-LC | MF-225 CUT-LC | MF-150 CUT-LC | |
| | Light Cutting Fiber One Step Pad (OSP) (No center hole) | | MF-625-OSP-LC | MF-525-OSP-LC | MF-325-OSP-LC | MF-225-OSP-LC | MF-150-OSP-LC | |
| | Microfiber Black Polishing Pad (No center hole) | | MF-625 POL-LC | MF-525 POL-LC | MF-325 POL-LC | | | |

PROFILE

Attachment method: Hook & loop

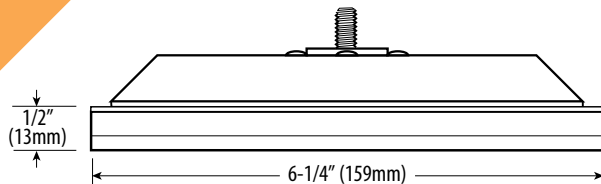

Backing plate: 43-148DAR

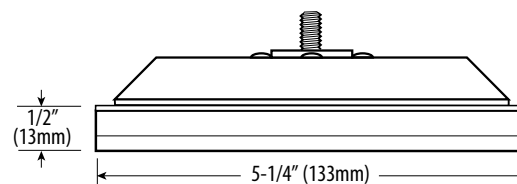

Backing plate: 43-125DAR

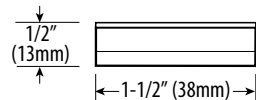
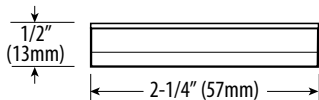

HDO
Microfiber

NEW & IMPROVED

One Step Pads are back with our revised microfiber material for faster cutting and a higher quality finishing ability!

ONE STEP PADS (OSP)

OSP Light Cutting/Heavy Polishing Microfiber Pads is designed to be used in conjunction with a DA polishing machine to help remove moderate defects, swirls, light oxidation, and holograms to provide a high gloss finish. OSP Microfiber utilizes a flexible foam layer firm enough for cutting and soft enough for finishing flat or contoured body panels.

PREMIUM WOOL PADS

KNITTED

QUICK TIP

Washing the lambswool removes the natural oils in the wool, adding cutting ability and ability for abrasives to cling to the wool fibers.

A GRADE ABOVE THE REST

The LC knitted wool pads are the finest in their class, created from only the highest grade wool and blend of materials. Compiled of a number of proprietary and different blended pads, we offer wool pad products available nowhere else in the world. Our knitted wool pads combine the performance benefits of traditional lambswool with the ability to blend materials to suit specific cutting or finishing needs, all while ensuring a consistent quality from pad to pad.

Knitted pads reduce the amount of shedding or linting compared to traditional wool pads. Our signature foamed wool pads are known around the world, and continue to gain popularity year over year. We pride ourselves on finding wool pad solutions from industrial applications to detailing and for all types of machines.



SIGNATURE FOAMED WOOLS

Ideal for body shop, detailing, OEM and industrial applications.

ONE STEP COMPOUNDING

Aggressively removes P1500 scratches and finishes to high gloss in one step. Cuts like natural sheepskin but finishes like a foam pad, leaving a lustrous finish with no haze.

NANO FOAMED WOOL TECHNOLOGY

Interlocking the wool fibers, a polyurethane foam is blended and embedded in the base of the knitted wool, creating more surface area and a reduction in pile flattening.

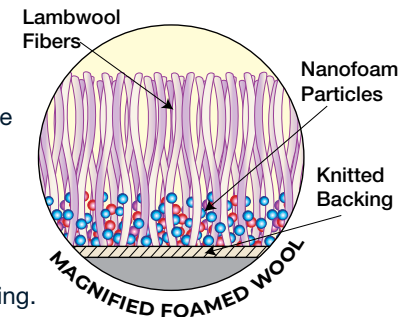

PREWASHED WOOL

Used in a variety of markets or applications, our premium knitted wool pads come in a variety of blends that make these pads ideal for any industrial application.

REDUCED LINT

Work cleaner and reduce contamination of the environment in body shop and OEM applications where it matters most.

CONSISTENT QUALITY AND CONSTRUCTION

Manufacturing process ensures uniform material unlike natural sheepskin which varies in consistency. Higher density product makes the material resist “caking & matting”.

LOW LINT KNITTED LINE

Premium low lint pads are a knitted prewashed lambswool paired with a foam interface for maximum comfort, performance and overall user feel/experience. Significant testing went into the design to determine the best weight & wool pile height to maximize this pad for peak performance on any type of machine.

RECOMMENDED TOOLS

- 01 RANDOM ORBITAL DA
- 02 ROTARY
- 03 FORCED DA

PRODUCT RANGE

| Low Lint Lambswool | Description | Size (W x H) | Part Number | Matching Backing Plate Size | Quantity |
|---|---|--------------|--------------|-----------------------------|----------|
|  | Low Lint Prewashed Knitted Lambswool 1/2" Wool w/ No Interface | 3-1/4 x 1/2" | LL-325-EC-LC | 3" | |
| | | 5-1/4 x 1/2" | LL-525-EC-LC | 4" | |
| | | 6 x 1/2" | LL-600-EC-LC | 5" | |
| | | 8 x 1/2" | LL-800-EC-LC | 7" | |
| | Low Lint Prewashed Knitted Lambswool 1/2" Wool 3/8" Foam w/ Interface | 3-1/4 x 7/8" | LL-92325-LC | 3" | |
| | | 5-1/4 x 7/8" | LL-92525-LC | 4" | |
| | | 6 x 7/8" | LL-92600-LC | 5" | |
| | Low Lint Prewashed Knitted Lambswool 1/2" Wool 3/8" Soft Foam w/ Interface | 8 x 7/8" | LL-72800-LC | 7" | |

PROFILE

Attachment method: Hook & loop

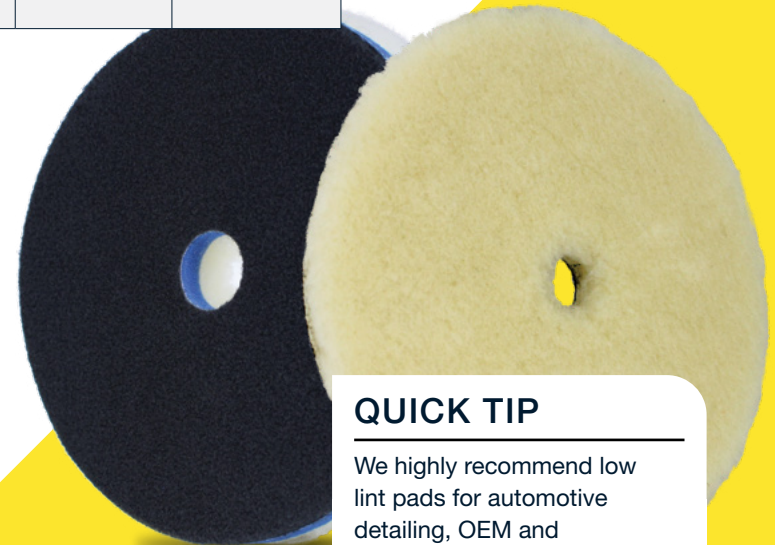
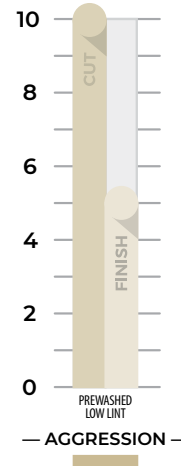
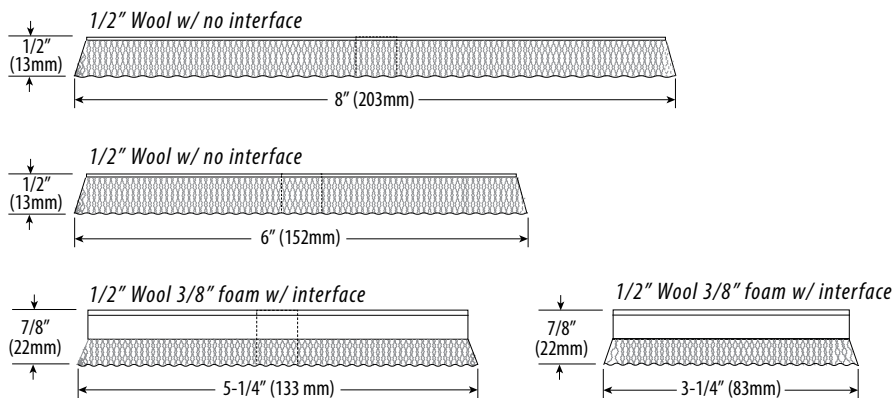

QUICK TIP

We highly recommend low lint pads for automotive detailing, OEM and industrial applications.

PURPLE FOAMED WOOL KNITTED LINE

RECOMMENDED TOOLS

02 ROTARY

03 FORCED DA

The purple foamed wool is a staple in the detail, OEM, and industrial markets alike. The proprietary foaming process helps hold the fibers together, creating a cushioned feel, holding abrasives to the surface, and adding an increased gloss and finishing ability. The patented nanofoam process encapsulates fibers at the base of the lambswool with microscopic polyfoam particles. Easily remove and level P1500 grit scratches, but still leave the finish of a foam pad, reducing holograms or compounding swirls.

PRODUCT RANGE

| Purple Foamed Wool | Description | Size (W x H) | Part Number | Matching Backing Plate Size | Quantity |
|---|---|--------------|-----------------|-----------------------------|----------|
|  | Purple Foamed Wool Buffing / Polishing Pad with Center Hole | 3-1/4 x 3/4" | | | |
| | | 5-1/4 x 3/4" | 58-32525WH-1-LC | 5" | |
| | | 6-1/4 x 3/4" | 58-32625WH-1-LC | 6" | |
| | | 7-1/2 x 3/4" | 58-3275-LC | 160MM or 175MM | |

PROFILE

Attachment method: Hook & loop

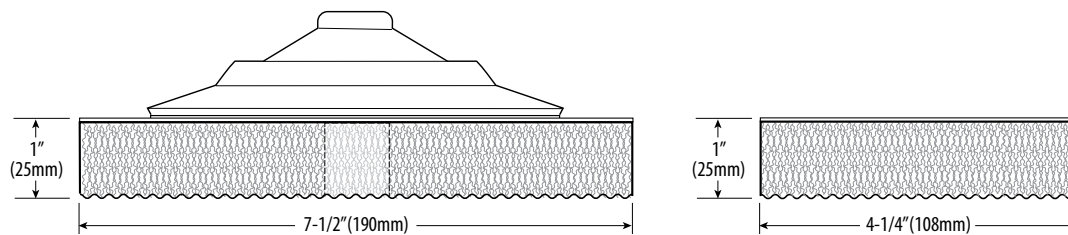

Backing plate: 43-160WH



BLUE FOAMED WOOL

RECOMMENDED TOOLS

02 ROTARY

03 FORCED DA

With the same great technology of our purple foamed wool pad, the blue foamed wool has a higher foam content for increased firmness and an even better finish. Offered in a 1" pile, this pad was originally designed as a cutting pad for gear driven and forced rotation polishers. The foamed wool fibers resist or reduce caking and matting down.

PRODUCT RANGE

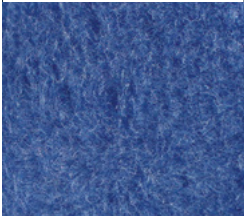
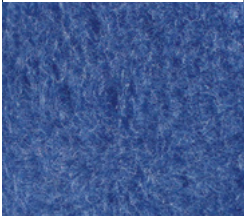
| Blue Hybrid Wool | Description | Size (W x H) | Part Number | Matching Backing Plate Size | Quantity |
|---|-----------------------------------|--------------|--------------|-----------------------------|----------|
|  | Blue Hybrid Wool | 3-1/4 x 1" | HYB-80-1-LC | 3" | |
| | | 4-1/4 x 1" | HYB-108-1-LC | 4" or 3" | |
|  | Blue Hybrid Wool with Center Hole | 5-1/4 x 1" | HYB-133-LC | 5" | |
| | | 6 x 1" | HYB-150-LC | | |
| | | 6-1/4 x 1" | HYB-159-LC | 6" | |
| | | 7-1/2 x 1" | HYB-178-LC | 7" or 6-1/4" | |

PROFILE

Attachment method: Hook & loop

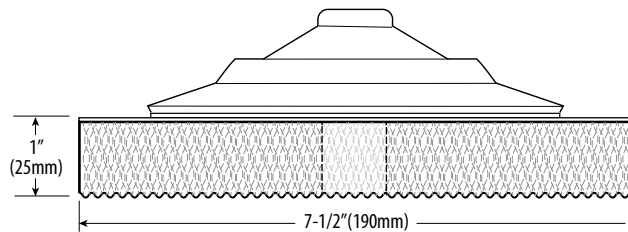

Backing plate: 43-160WH

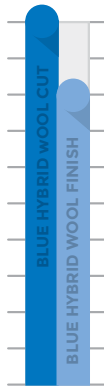

- AGGRESSION -

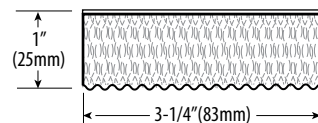
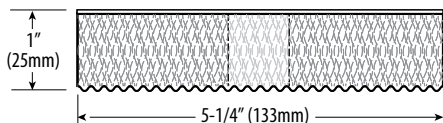
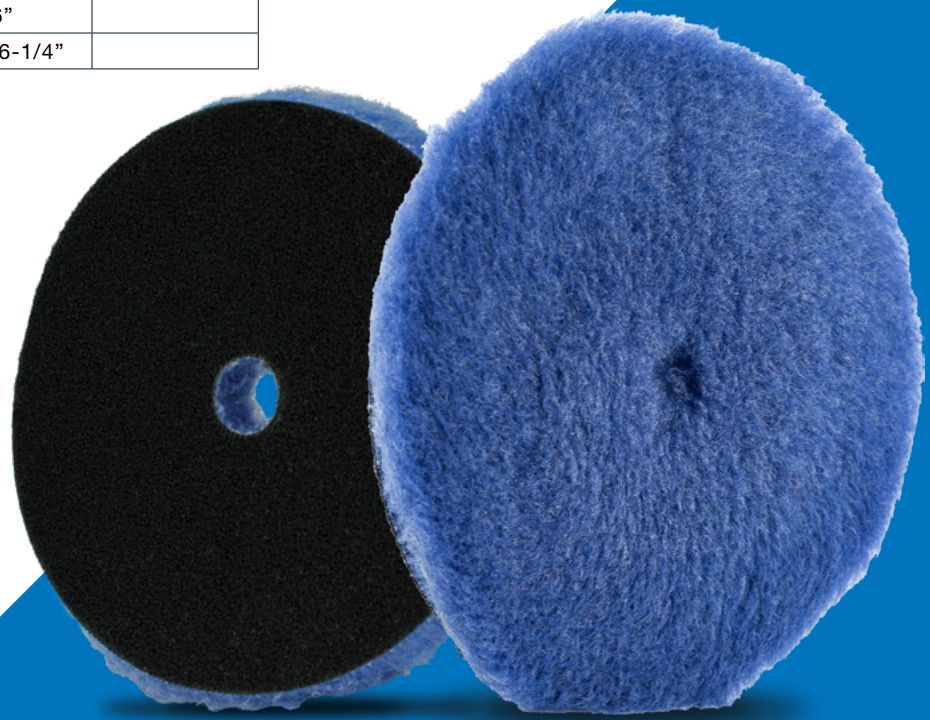

A GRADE ABOVE THE REST

TRADITIONAL WOOL PADS

Tufted wool is a traditional and aggressive cutting material used in pad construction that has been used in the industry for years, making it one of the best selling pads overall. Tufted wool is available in a variety of options.

TUFTED WOOL AGGRESSION CHART

Each bar color coordinates with the applicable pad color.

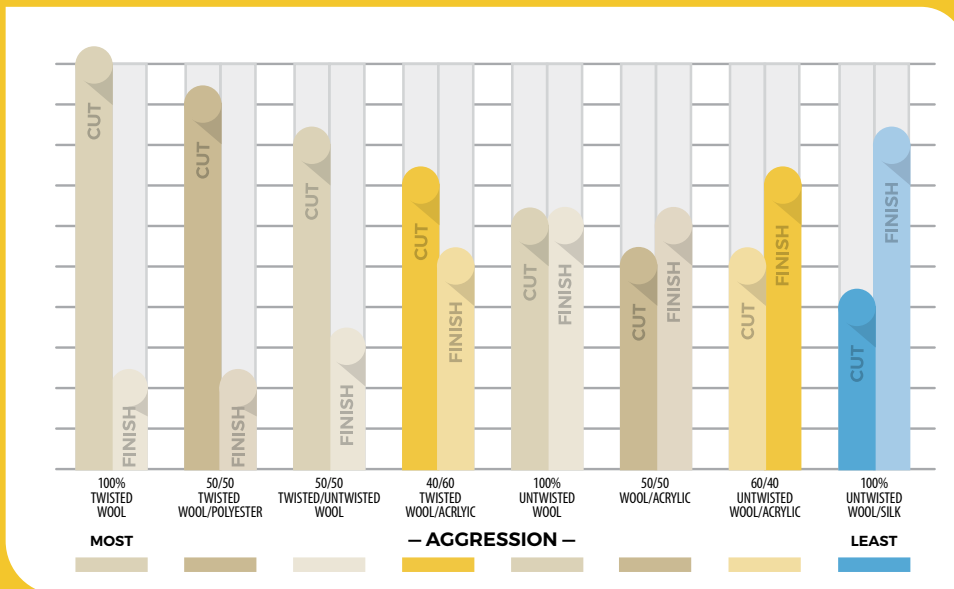

QUICK CUTTING

Engineered wool and other yarns are the fastest cutting products.

DURABLE AND STRONG

Signature backing construction and material blends offer a pad with extended durability.

CURVED EDGE

Allows for perfect pad alignment while protecting the working surface.



PRODUCT RANGE

| Traditional Wool Pads | Description | Thickness | Part Number | Matching Backing Plate Size |
|---|---|-----------|-------------|-----------------------------|
|  | White Steamed Twisted 100% Wool Pad | 1-1/2" | 35-222-LC | 8" |
|  | Yellow Steamed Twisted Wool / Acrylic Pad | 1-1/2" | 35-555-LC | 8" |
|  | Curved Edge 100% Unsteamed Twisted Wool Pad | 1-1/2" | 41-125-LC | 7" |
| | | 1-1/4" | 41-025-LC | 7" |
| | | 1" | 41-005-LC | 6" |
| | | 1-1/2" | 41-125A-LC | 6" |
|  | 40/60 Unsteamed Twisted Wool / Acrylic Pad | 1-1/2" | 41-355A-LC | 7" |
| | | 1" | 41-345A-LC | 6" |
|  | 50% Twisted 4-Ply Wool | 1-1/2" | 41-425-LC | 7" |

RECOMMENDED TOOLS

02 ROTARY

Tufted wools come in what seems like an endless variety of sizes, blends, and even construction. Lake Country is the only wool pad manufacturer to offer both steamed and unsteamed wool pads to fit anyone's need or intended purpose. Each style of pad offers different performance and feel, creating a following for both styles throughout the world.

Steamed pads typically have less wool material, and are lighter in weight. The steaming process swells or blooms the wool strands to fill in the pad, and lock in some of the loose fibers of the pad. This helps reduce the linting of the wool and makes the strands stay more vertical.

Unsteamed wool pads are sewn with more wool which provides more material to cut. Wool strands lie flat or horizontal so leveling sand scratches is easy. We offer a number of blends, so the cut and finish can be altered to the user's preference.



ATTACHMENT METHODS

ROTARY & DA PLATES

Extra soft polyurethane plates conform to panels, creating a smooth, unmatched performance and feel. The unique polyurethane density allows the user to adjust pressure to fit their technique.

Premium molded, high strength backing plates offer a full range of sizes and shapes for tools and various uses. Highly flexible and agile, these plates create a different feel than an extra soft polyurethane plate.

While our molded urethane are more rigid and dense material, they offer a very flexible option when polishing in concaved or very curved panels. The plate offers a balance of structure and flexibility, offering increased performance in all industries including composites.

DURABILITY

High quality, molded urethane create a durable, long lasting plate.

PERFECTLY BALANCED

Perfectly molded urethane for a smooth, balanced experience.

UNIVERSAL

Options of 14mm, 16mm, 5/16" and 5/8" threads, we have a plate to fit any need or pad size.



WHITE EXTRA SOFT EDGE ROTARY BACKING PLATES

The white ultra-dense urethane not only can easily glide over all surfaces but is extremely durable as well.

| White Extra Soft Edge Rotary | Thread Size | 6" | 5" | 3" | 2" | 1" |
|---|-------------|-----------------------|---------------------------|--------------------------|----------------------|----------------------|
| | | Dimensions 150mm (6") | Dimensions 125mm (4-3/4") | Dimensions 73mm (2-7/8") | Dimensions 50mm (2") | Dimensions 25mm (1") |
|  | 14mm | 45-936-14MM-HTE-LC | 45-929-14MM-HTE-LC | 45-175-14mm-LC | 45-150-14mm-LC | 45-100-14mm-LC |
| | 5/8" x 11 | 45-936-LC | 45-929-LC | 45-175-LC | 45-150-LC | 45-100-LC |
| RECOMMENDED TOOLS | | 02 ROTARY | | | | |





BACKING PLATE ADAPTERS

Easily modify your rotary backing plate to be used on a Dual Action polisher or a drill with Lake Country adapters. Each adapter includes a washer.

URETHANE ROTARY BACKING PLATES

High strength molded urethane helps absorb the heat created while also allowing flexibility over the buffing surface.

| Urethane Rotary | Thread Size | 7" | 6-1/4" | 6" | 5" | 3" |
|--|-------------|---------------------------|---------------------------|-----------------------|---------------------------|--------------------------|
| | | Dimensions 175mm (6-7/8") | Dimensions 160mm (6-1/4") | Dimensions 150mm (6") | Dimensions 125mm (4-3/4") | Dimensions 73mm (2-7/8") |
|  | 14mm | | 43-160WH-14MM-LC | M43-150-14MM-LC | 43-125WH-14MM-LC | 43-073-14MM-LC |
| | 16mm | | 43-160WH-16MM-LC | 43-150-16MM-LC | | |
|  | 5/8" x 11 | 43-175M-BG-LC | 43-160WH-BG-LC | 43-150-BG-LC | 43-125WH-BG-LC | 43-073M-BG-LC |

URETHANE DA BACKING PLATES

| Urethane DA | Thread Size | 6" | 5" | 3-1/2" | 3" |
|---|-------------|---------------------------|---------------------------|--------------------------|--------------------------|
| | | Dimensions 148mm (5-7/8") | Dimensions 125mm (4-7/8") | Dimensions 85mm (3-1/2") | Dimensions 73mm (2-7/8") |
|  | 5/16" x 24 | 43-148DAR-LC | 43-125DAR-LC | 43-085DA-LC | 43-073DA-LC |
| RECOMMENDED TOOLS | | 02 RANDOM ORBITAL DA | | | |



DETAILERS BACKPACK

The LCPT Backpack allows you to keep your hands free and transport your polishers and products safely on your back.

Gone are the days of lugging around heavy duty style bags with products and polishers scattered inside, causing possible damage to your machines.

With the LCPT Backpack your polishers and products are securely held in their designated spots.

| Description | Part Number |
|--------------------|-------------|
| Detailers Backpack | 25-0403 |



BUILT FOR COMFORT AND DURABILITY

The LCPT backpack is engineered and designed to be carried without fatigue. It features padded shoulder straps and multiple pads that rest the backpack easily on your back.



KEEPING DETAILERS EFFICIENT AND HANDS-FREE

Free up your hands and carry all of your polishers and products safely on your back. Featuring a Blow Molded Durable Bottom Shell
Your polishers and products are protected from drops, as well as allowing the backpack to stand upright so you can safely load and unload your tools.



ENGINEERED POCKET SYSTEM WITH STAIN RESISTANT INTERIOR

Carry all of your detailing accessories safely inside! Two full size and one 3" polisher have designated spots and are securely held in place. You can also fit brushes, tools, pads, towels, and even your compound and polish.

ACCESSORIES



ROTARY EXTENSIONS

Reach in tight and difficult areas with Lake Country’s rotary extensions. Made of precisely machined high quality stainless steel, these extensions are developed to perform without wobble, skipping, or hopping.

Each kit contains a 6” and 3” extension, combine to make 9” of total extension.

| Description | Part Number |
|---------------|-----------------|
| Extension Kit | EXT-KIT 1/2”-LC |



PRECISION APPLICATORS

With a versatile shape, precision applicators are designed to access a variety of tight spaces with a comfortable, easy to grip handle.

| Description | 3.75” |
|---|--------------------|
| Yellow Precision Scrubber w/ Handle | 89-200 SCRUB YL-LC |
| Black Precision Dressing Applicator w/ Handle | 89-200 DRESS BK-LC |
| Red Precision Applicator w/ Handle | 89-200 APP RD-LC |



MICROFIBER TOWELS

Korean microfiber towels that are great for both drying and removing residue. Available in 4/bag or 50/bag. Combo blue & gold is only available as 4/bag.

| Description | 16 x 16" |
|--|--------------|
| Microfiber Detailing Cloth (2 Blue & 2 Gold) | 87-210-LC |
| Microfiber Detailing Cloth (Blue) | 87-210BBL-LC |
| Microfiber Detailing Cloth (Gold) | 87-210GO1-LC |
| Microfiber Detailing Cloth (Navy Blue) Edgeless | 87-210BNB-LC |



SNAPPY CLEAN BOOST™

A concentrated cleaner that releases wax and polish from the foam or wool pads with just a few minutes of soaking. Biodegradable, non-flammable, and rinses out easily.

| Description | Part Number |
|--|-------------|
| Snappy Clean Boost™ (Citrus 1.25 oz. packet) | 92-003 |
| Snappy Clean Boost™ 5l bucket | 92-002-5l |

LAKE COUNTRY

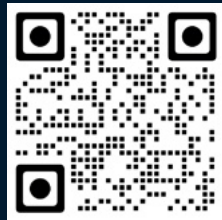

LAKE COUNTRY MANUFACTURING, INC

950 BLUE RIBBON CIR N, OCONOMOWOC, WI 53066 USA
WWW.LAKECOUNTRYMFG.COM | CONTACT PHONE: (262) 367-8395